

Detail systeme de fixation
Ech 1:2

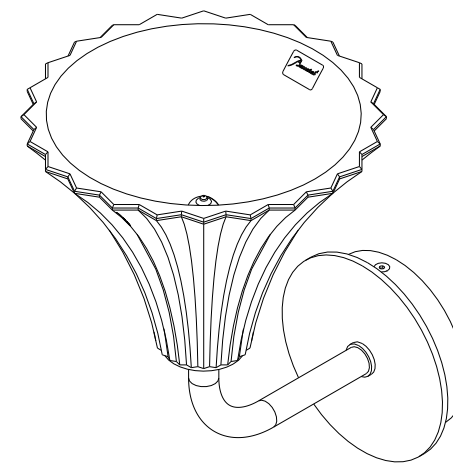
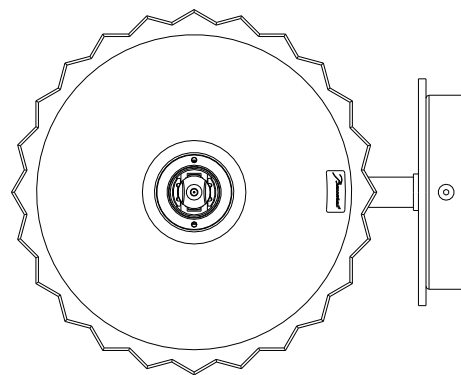
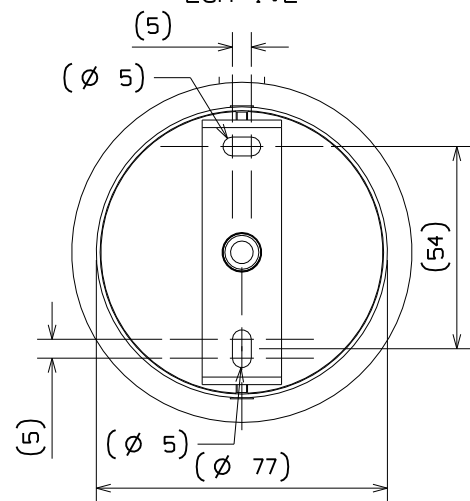

Baccarat
MILLE NUITS
MILN-APPL TULIPE JET

60W
100-127V~ 50/60Hz
- G9 1 X MAX 60W

IP20
ta: 25°C

Manufactured by *Baccarat*
54120 Baccarat FRANCE

| Code | Designation | Couleur |
|---------|-----------------|---------|
| 2106056 | APPL TULIPE JET | CCL |
| 2106057 | APPL TULIPE JET | BLEU |
| 2106058 | APPL TULIPE JET | PIVOINE |
| 2106059 | APPL TULIPE JET | RUBIS |
| 2106060 | APPL TULIPE JET | VERTE |
| 2106061 | APPL TULIPE JET | AMBRE |

| | | | | |
|-----------------|----|-------------------------------------------------------------------------------------------------------------------------------------------------------------------|----------------|-----------------------------------------|
| Ech. Scale: 1/3 | A3 | POIDS / WEIGHT: 1050 gr | DATE: 03.01.11 | FOLIO: 1/1 |
| | | Siege Social et Manufacture / Head Office and Factory : 20, rue des cristalleries - 54120 BACCARAT Tel. +33 (0)3 83 76 60 06 Telecopie +33 (0)3 83 76 60 04 | | |
| | | PLAN D'ENSEMBLE / GLOBAL DRAWING: | | NUMERO PLAN / DRAWING NUMBER: 143773 |