

DÉVELOPPEMENT PRODUITS
07 FEVRIER 2018

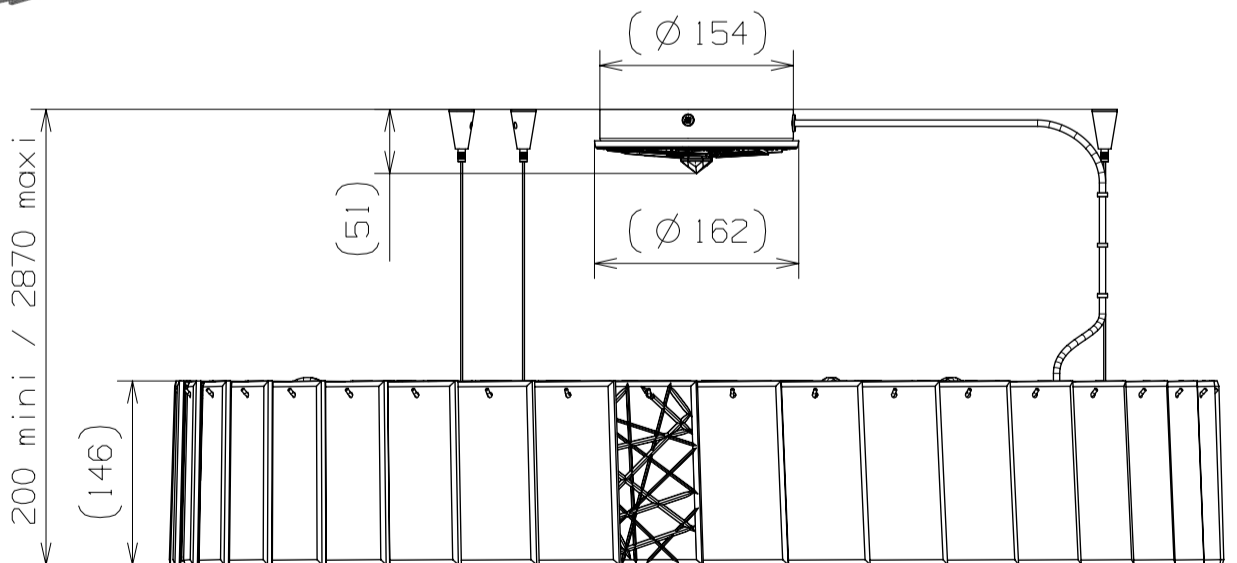

Baccarat
TUILE DE CRISTAL 2812350
TUIL-PLAF JET FROZ

507W
100-120V~ 50/60Hz
- E26 3 X MAX 40W
- E26 9 X MAX 43W

IP20
ta: 25°C

Manufactured by *Baccarat*
54120 Baccarat FRANCE

CODE 2812350

Ech. Scale: 1/6 A3

POIDS / WEIGHT: env. 22Kg

DATE: 07.02.18

FOLIO DP: 1/1

Baccarat

Siege Social et Manufacture / Head Office and Factory :
20, rue des cristalleries - 54120 BACCARAT
Tel. +33 (0)3 83 76 60 06 Telecopie +33 (0)3 83 76 60 04

PLAN D'ENSEMBLE
GLOBAL DRAWING:

NUMERO PLAN / DRAWING NUMBER:

TUIL-PLAF JET FROZ

157771

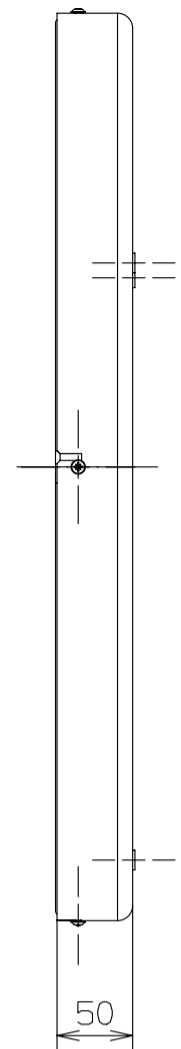
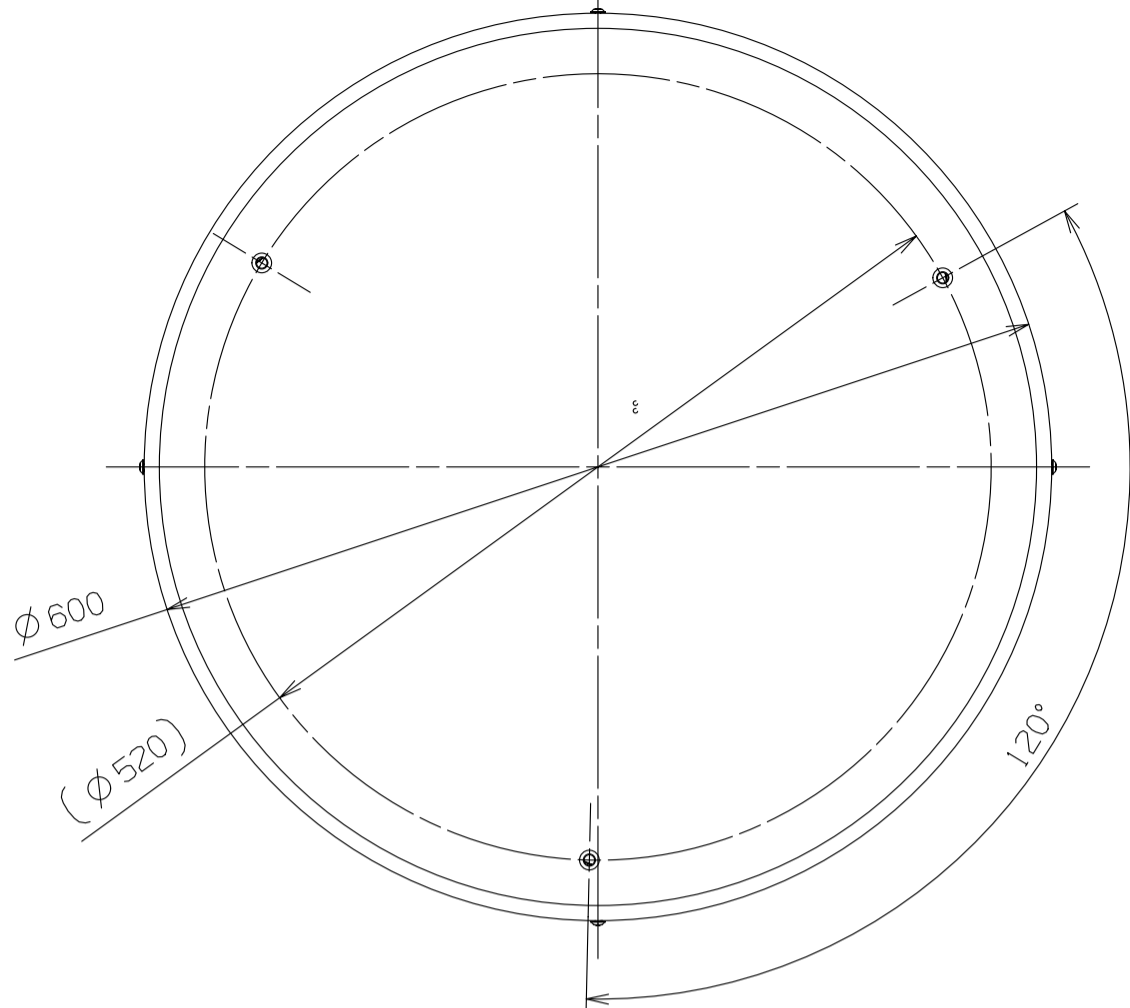

Vue ISO:

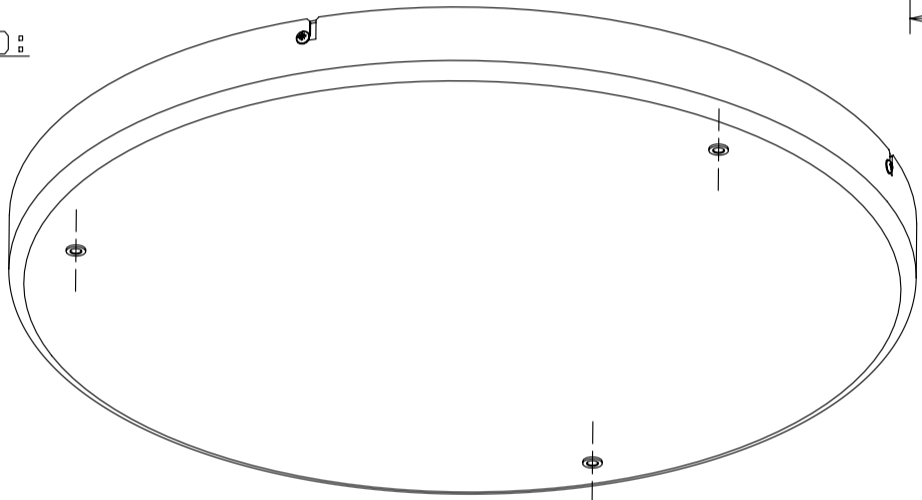

Fixation:

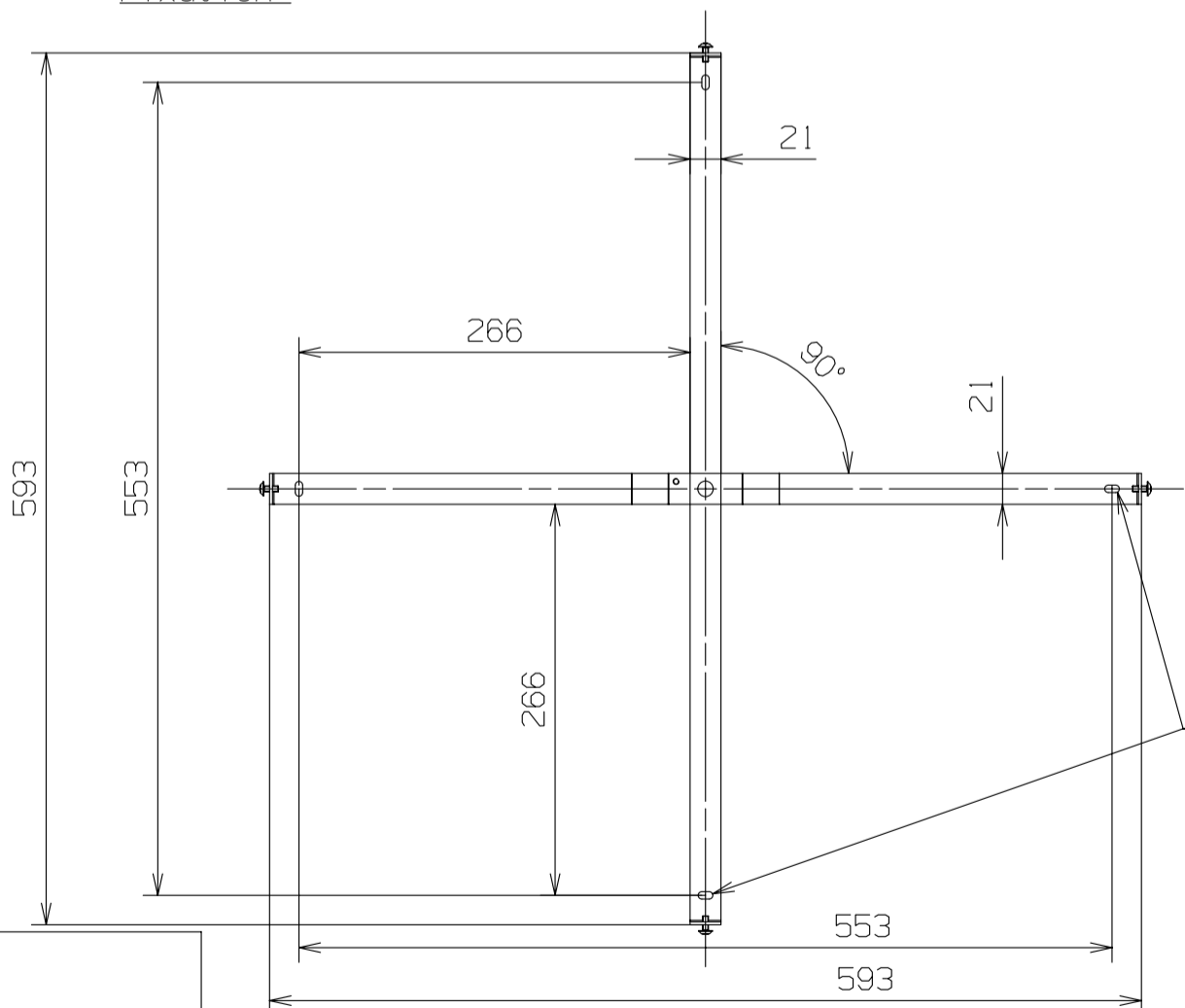

CODE 2801300

Baccarat
CACHE 2801300
CCIR 600 X3
 100-240V~
 Manufactured by *Baccarat*
 54120 Baccarat FRANCE
 04/09/2012

Ech. Scale: 1/5 | A3 | POIDS / WEIGHT: 6 Kg | DATE: 08.08.12 | FOLIO DP: 1/2

Baccarat | Siege Social et Manufacture / Head Office and Factory :
 20, rue des cristalleries - 54120 BACCARAT
 Tel. +33 (0)3 83 76 60 06 Telecopie +33 (0)3 83 76 60 04

PLAN D'ENSEMBLE GLOBAL DRAWING: | NUMERO PLAN / DRAWING NUMBER:
 CCIR 600 X3 | 151077

Exemples de montages possibles:

- Avec 3 suspensions TORCH Abat-jour blanc (2 605 299)

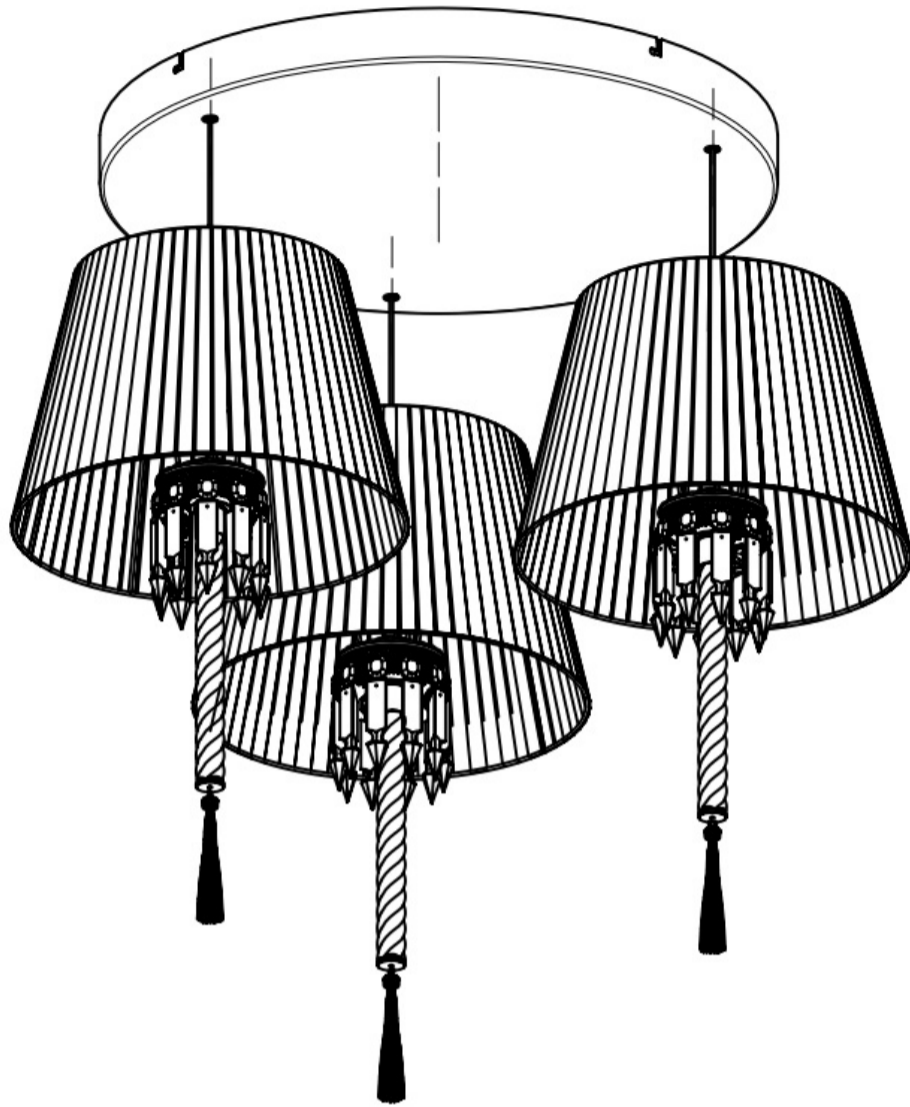

- Avec 3 suspensions TORCH Abat-jour noir (2 605 736)

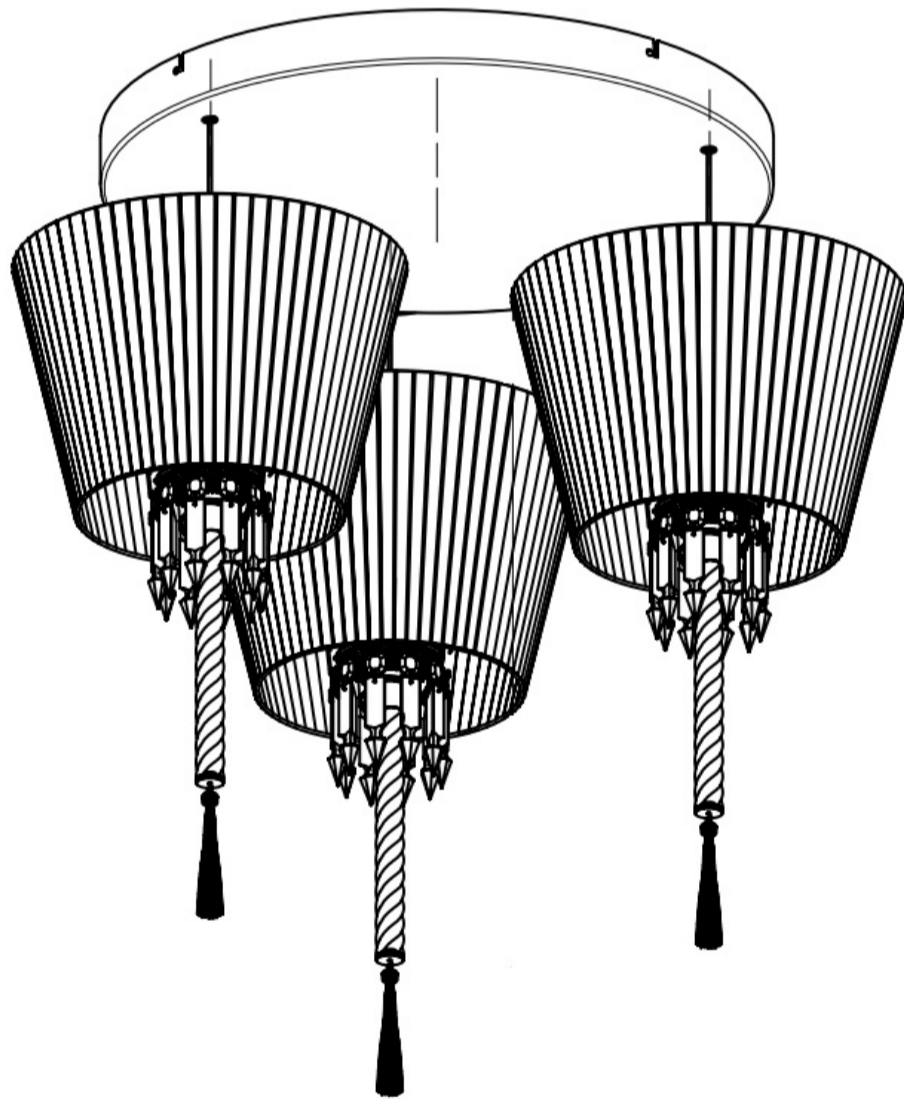

CODE 2801300

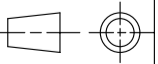
| | | | | |
|---|----|---|----------------|---|
| Ech. Scale: | A3 | POIDS / WEIGHT: 6 Kg | DATE: 08.08.12 | FOLIO DP: 2/2 |
|  | | Siege Social et Manufacture / Head Office and Factory : 20, rue des cristalleries - 54120 BACCARAT Tel. +33 (0)3 83 76 60 06 Telecopie +33 (0)3 83 76 60 04 | |  |
| | | PLAN D'ENSEMBLE GLOBAL DRAWING: | | |
| | | | | 151077 |