

Detail Beliere
Ech. 1:2

DÉVELOPPEMENT PRODUITS
20 janvier 2017

CODE 2811568

Baccarat
MILLE NUITS 2811568
MILN-PLAF JET GM 04X25W

100W
100-120V~ 50/60Hz
- G9 4 X MAX 25W

IP20
ta: 25°C

Manufactured by *Baccarat*
54120 Baccarat FRANCE

Ech. Scale: 1/5	A3	POIDS / WEIGHT: 12Kg	DATE: 20.01.2017	FOLIO DP: 1/1
		Siege Social et Manufacture / Head Office and Factory : 20, rue des cristalleries - 54120 BACCARAT Tel. +33 (0)3 83 76 60 06 Telecopie +33 (0)3 83 76 60 04		
		PLAN D'ENSEMBLE GLOBAL DRAWING:		NUMERO PLAN / DRAWING NUMBER: 157068
MILN-PLAF JET GM 04x25W				

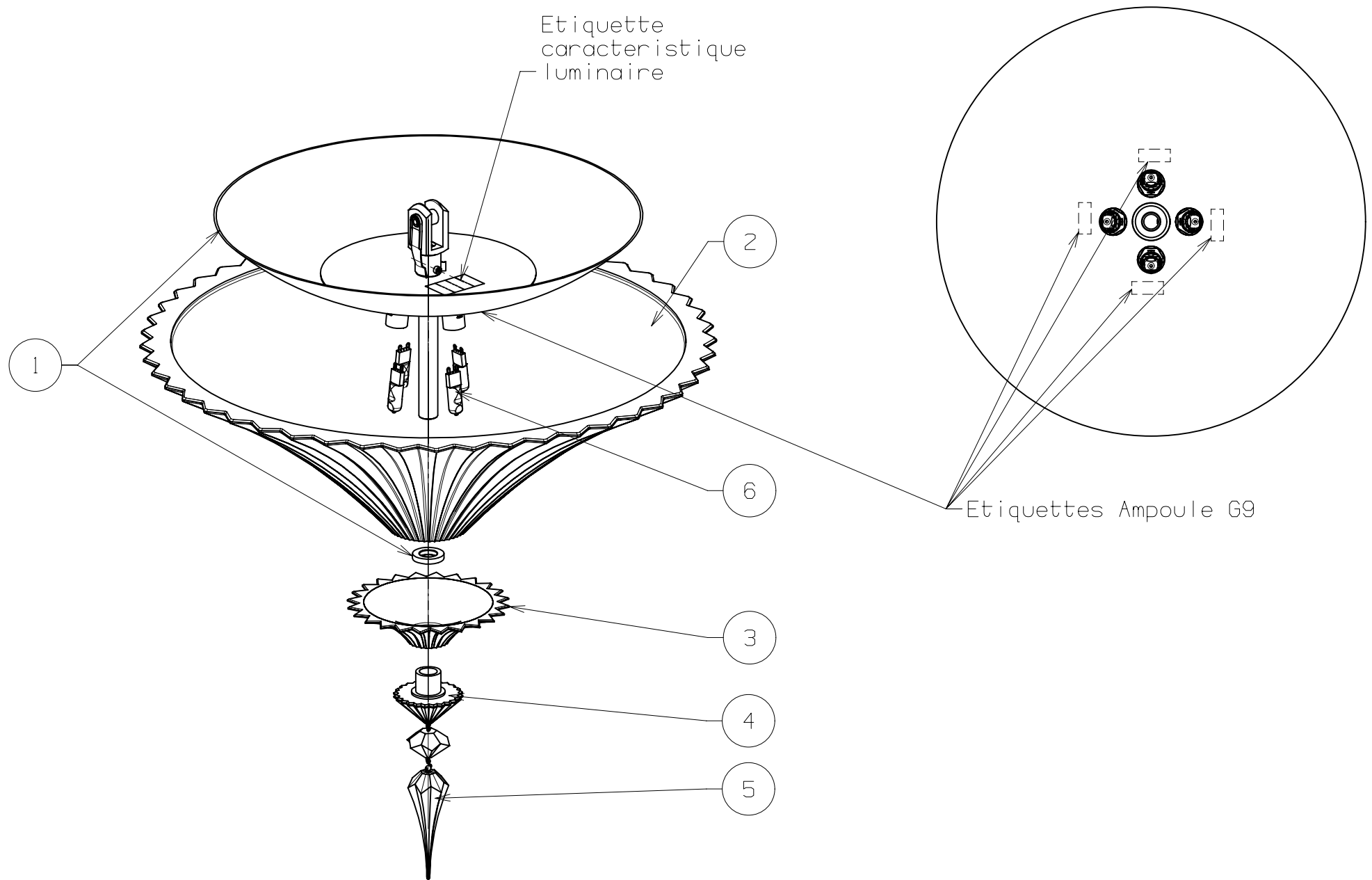

DÉVELOPPEMENT PRODUITS
20 janvier 2017

Rep	Nbr	CODE	N° PLAN	Designation
/	2	5051901	145334	ETIQUETTE LUMINAIRE 30x48
/	1	5059691	-	NOTICE LUSTRE TRADIT
1	1	5215846	157071	MILN-SE PLAF K A REF03
2	1	5215845	157070	MILN-SE CPE 550 PLAF CR
3	1	5029312	141248	MILN-BOBECHE F24
4	1	5065630	148644	MILN-SE CACHECROU C
5	1	5065636	148724	MILN-SE PEND PRIS B
6	4	5059800	146024	AMPOULE G9 120V 25W

CODE 2811568

Ech. Scale: 1/1		A3		POIDS / WEIGHT: 12Kg						
MODIFICATIONS										
	A	Diffusion du plan		20.01.17	LAUMONNERIE					
IND.	DESIGNATION			DATE	NOM/NAME	IND.	DESIGNATION		DATE	NOM/NAME
		Siege Social et Manufacture / Head Office and Factory : 20, rue des cristalleries - 54120 BACCARAT Tel. +33 (0)3 83 76 60 06 Telecopie +33 (0)3 83 76 60 04								
		CE PLAN EST NOTRE PROPRIETE ET NE PEUT ETRE COMMUNIQUE A DES TIERS SANS NOTRE AUTORISATION ECRITE THIS DRAWING IS OUR PROPERTY AND CAN NOT BE GIVEN OUT TO THIRD PARTIES WITHOUT OUR WRITTEN PERMISSION								
PLAN D'ENSEMBLE GLOBAL DRAWING:		MILN-PLAF JET GM 04x25W				NUMERO PLAN / DRAWING NUMBER:		FOLIO:		
						157068		1/1		
								INDICE INDEX: A		